

National Super

This comprises two outer walls, two inner walls, two top locking bars and two bottom locking bars. Also supplied are a pair of frame runners and/or castellated spacers and a pack of nails. The outer walls each have two long grooves and 4 cut out slots, the inner walls are plain and slightly smaller.

1. Start by attaching a frame runner to each of the inner walls. Attach the runner to one edge of the inner wall using the brass escutcheon pins ensuring that the runner is spaced equally from each end of the side wall. If assembling a standard super, ensure the runners are attached to the same edge of the inner wall that has a sawcut along its length. Attach the runner so that it is on the face of the inner wall furthest from the saw cut.

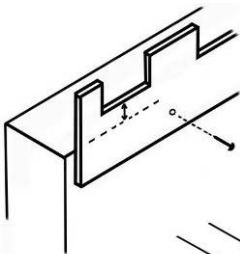
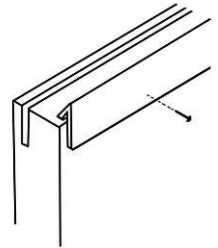

N.B. If assembling a Budget super, there are no saw cuts in the inner wall and frame runners are not used. In this case the castellated spacers are nailed centrally on one side of the inner walls, using brass escutcheon pins. The castellated spacer cut-outs must project above the inner wall by 1/4".

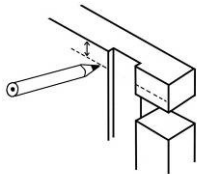

2. Mark the outer wall 7/16" down, adjacent to the long groove

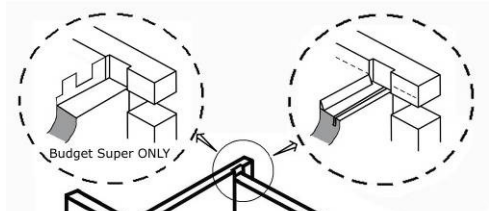

3. Apply glue to the grooves in the outer walls and then push the inner boards into the groove, ensuring top of runner coincides with mark. If assembling a Budget super, the top of castellated spacers must be flush with the top of box.

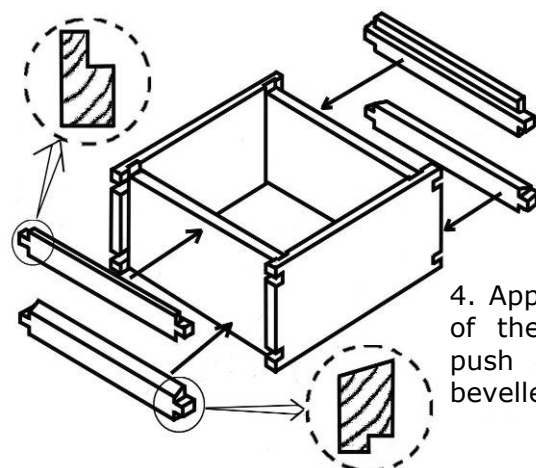
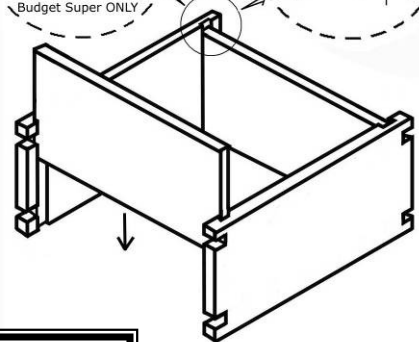

Check regularly that the box is square

4. Apply glue to the inner faces of the locking bars and then push them into the slots, bevelled type at the bottom.

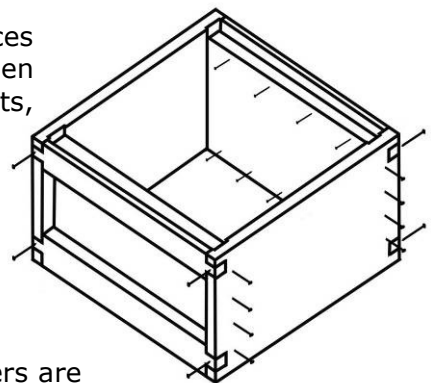

5. Nail through outer walls into inner walls using 2" nails. Nail locking bars into position using 2" nails. Nail locking bars from inside 3/16" down from runner, using 1 1/2" nails.

When assembly of the super is complete, the castellated spacers are fitted by pushing into the sawcut.